

XZ27E
Issue 1

SuperScan MK II

Uses Surface Mount Technology

Design by Chris Barlow G8LVK
Text by Chris Barlow and Maurice Hunt

Superscan MkII is an improved, easier to build and more compact version of the acclaimed Superscan Active Aerial. This is an advanced design of HF/VHF and UHF Wideband Active Aerial, using sophisticated surface-mount technology and microstrip PCB design to provide optimum signal reception strength across a very wide bandwidth, making it perfect for use with scanning receivers having an external aerial input connector. Unlock the hidden potential of your radio receiver!

FEATURES

Indoor or outdoor use

Wideband HF/VHF/UHF preamplifier

Low power consumption

High gain

Power supply through coaxial cable

Uses Surface Mount Technology

APPLICATIONS

Ideal for scanning receivers

VHF and UHF Aircraft bands

VHF Marine band

HF/VHF/UHF Amateur Radio bands

VHF Taxi band

SPECIFICATION

Aerial Specification

Power supply: +9V to +14V DC
Supply current: 17mA (@ +12V DC)
Frequency range: 1MHz to 2,000MHz (2GHz)
Gain: 19dB (maximum)
Impedance: 50Ω
Connector: N type
Length: 75cm
Weight: 0.25kg
Mast clamp: 51mm (2in.) Maximum diameter mast

PSU Interface Specification

Power supply: +9V to +14V DC
RF Insertion loss: -1dB at 500kHz and 1,000MHz (1GHz)
50Ω
Input/Output Impedance: 50Ω
DC Connector: 2.5mm DC Power
RF Connectors: N / BNC

The assembled SuperScan MKII Aerial.

Preamplifier frequency response as shown on a spectrum analyser.

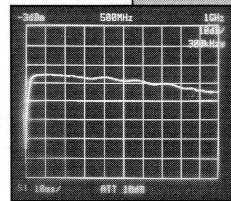

Typical receiving set-up.

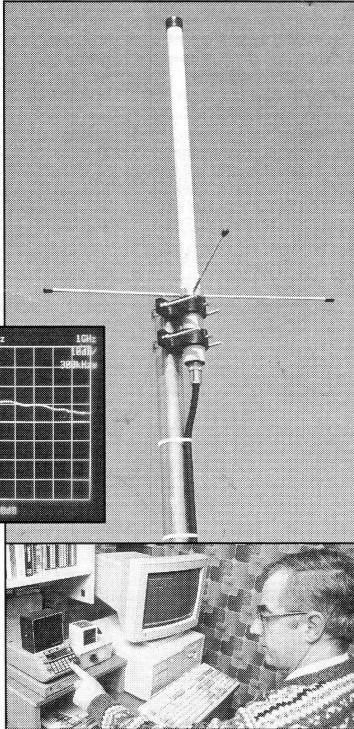

PROJECT RATING 2

The original Super Scan aerial (IT27E) made its debut in the May 1995 issue (No.89) of *Electronics*, and from its initial launch, it has proved to be an extremely popular kit. However, just about anything can be redesigned and improved. The new Super Scan aerial uses the same surface mount technology as the original, but has the following improvements;

- ◆ No more visits to your local DIY shop for plastic waste pipes, the aerial housing is pre-manufactured and included in the kit.
- ◆ No more fiddly wire aerial elements to thread up, the aerial elements are etched into the PCB.
- ◆ No more drilling of the PSU Interface box, this too is pre-manufactured and included in the kit.
- ◆ Smaller size, lighter construction, higher performance, and easier build all go to make the new Super Scan MKII even better value for money.

Although the small antennas usually fitted to scanners and other receivers are adequate for local reception of strong signals, for long distance (DX) or weaker signal reception, an external aerial, mounted as high as possible and preferably outdoors, is required. With the ever-increasing frequency range coverage of modern VHF/UHF scanners, a very broadband aerial is needed to enable the receiver's full potential to be realised. The Superscan MkII Active Aerial enables you to extract the best possible performance and hence, value, from your receiver, and will provide far superior reception than the standard-fitment 'rubber duck' type aerial found on most scanners.

Additionally, the interconnecting cable linking the aerial to the scanner must have low-loss signal characteristics if the advantages of using an external aerial are to be obtained. All cables will have some losses, which increase with feeder length and frequency. To compensate for this requires the aerial to incorporate signal gain; passively, this can be achieved by increasing the number of elements, reducing bandwidth and making the aerial directional - features not desirable in a scanner aerial system. A well-designed active aerial system solves all these problems, by using a wideband masthead signal amplifier to boost the incoming signals without the need for a directional aerial. The DC voltage used to power this amplifier is fed up through the centre core of the coaxial cable, which is introduced by using a PSU Interface at the receiver end.

The aerial described in this article features a weatherproof plastic housing, ideal for outdoor use, but equally suited for use indoors, and is compact enough to be unobtrusive when attached to a building or wall.

If you don't have the time or tools to build the kit, then the ready-made version (AM37S) is for you, and includes the following items:

- ◆ The Super Scan aerial and PSU Interface
- ◆ 230V AC Mains to +12V DC power supply
- ◆ Ready-made coaxial cables
- ◆ Two coaxial plug adaptors (N-type and PL259)
- ◆ Cable tie pack
- ◆ Installation guide

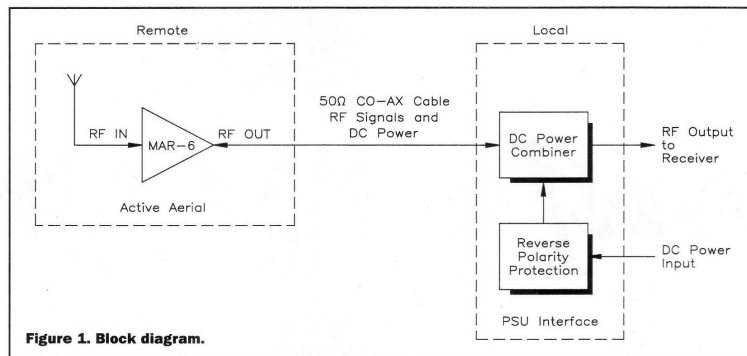

Figure 1. Block diagram.

Circuit Description

In addition to the system block diagram detailed in Figure 1, the circuit diagrams of both the aerial and the PSU Interface unit are shown in Figure 2. These should be of assistance in following the circuit description, or with faultfinding in the completed unit.

The passive aerial elements are etched into the PCB as a pattern tracks of differing lengths, resulting in a wider frequency coverage. In addition, the tracks are used to form some phantom components, namely, capacitors and inductors. A section of track on both sides of the PCB will form a capacitor, with the fibreglass board acting as the dielectric.

A spiral track will act as an inductor and when combined with a phantom capacitor, will form a series or parallel tuned circuit.

There is only one active component used in this part of the circuit, a MAR-6 RF amplifier integrated circuit, IC1, shown in Figure 3. This component is a Surface Mount Device (SMD) and because of its small size, any stray capacitive or inductive effects are minimised, thus maximising the performance of the circuit. The MAR-6 is a Monolithic Microwave Integrated Circuit (MMIC). This device is used as a 50Ω input/output amplifier with low noise and high gain characteristics, with an upper frequency response in excess of 2,000MHz (2GHz) - see inset header

photo on page 21. The signal input is on pin 1 and its output is on pin 3, with pins 2 and 4 used as ground returns.

The RF signals picked up by the aerial tracks are connected to pin 1 of IC1 and the amplified output appears on pin 3. This is connected to a track used to provide a 50Ω output line and the DC power input to the MAR-6. The end of this track is attached to an N-type coaxial chassis socket, SK1. The centre conductor of the coaxial cable carries both the positive voltage required to power the circuit and the amplified output signal of the aerial. The ground connection of SK1 is returned to the PCB through the metal end block at the base of the PCB assembly.

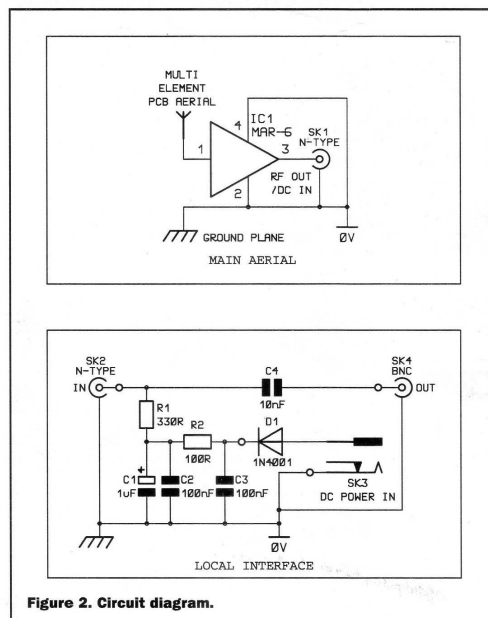

Figure 2. Circuit diagram.

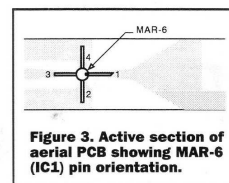

Figure 3. Active section of aerial PCB showing MAR-6 (IC1) pin orientation.

The active aerial is powered from the PSU Interface circuit, which splits off the amplified received RF signals to the radio receiver's aerial input. The external power supply required by the system is applied to SK3, with the positive voltage on its centre pin. This supply must be within the range of 9 to 14V and to prevent any damage caused by reverse polarity connection, diode D1 is used. D1 only conducts when the positive supply voltage is applied to its anode, allowing the DC power to pass to the rest of the circuit.

Capacitors C1, C2, C3 and resistor R2 provide the main RF decoupling for the +V supply rail. This is combined with the incoming received RF signals

on the centre pin of the second N-type socket SK2 via R1. The RF signals are AC coupled via C4 to the BNC output socket SK4.

Aerial PCB Construction

Before the SMD component, IC1, is soldered onto the board, the PCB must first be prepared. This is achieved by soldering two pieces of brass angle strip to the ground plane tracks, as per Figure 4.

The following steps should be carried out to ensure correct installation of these strips, as they provide both mechanical and electrical stability.

- Using a small hacksaw, cut two pieces of brass angle from the length provided in the kit. The first should be 105mm and the second 40mm.
- Using a small flat needle file, or some fine abrasive paper, remove any brass swarf from the ends of each strip.
- Using a polishing block (HX04E), or some fine abrasive paper, remove any tarnish from the surface of the brass.
- Lay the aerial PCB (component side up) on a heat resistant surface.
- Position the longer 110mm strip between the PCB markers and over the central 50Ω output track.
- Using a 25 to 50W or butane/gas type soldering iron (fitted with a large bit), solder down each side of the brass angle strip, bonding it to the ground plane tracks of the PCB.
- When cooled, turn over the PCB and position the shorter 40mm brass strip over the hole at IC1 and at the end of the ground plane track. Solder down each side to bond it to the PCB.

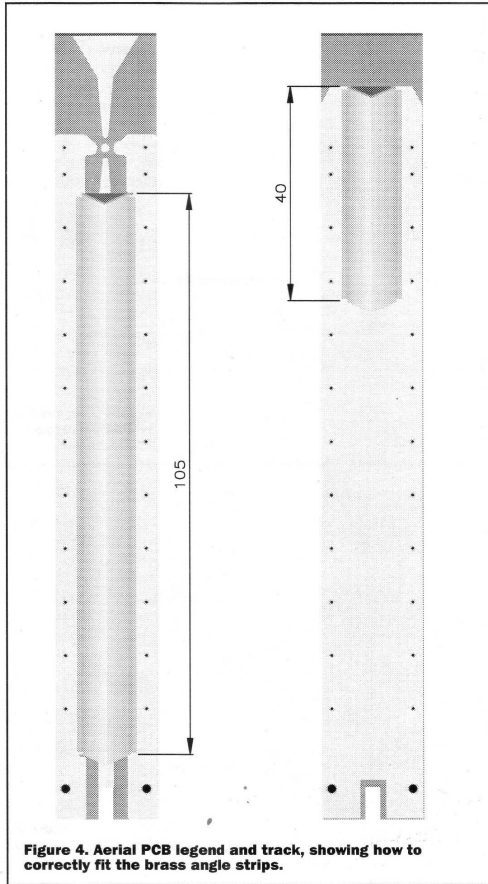

Figure 4. Aerial PCB legend and track, showing how to correctly fit the brass angle strips.

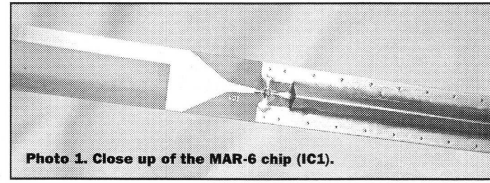

Photo 1. Close up of the MAR-6 chip (IC1).

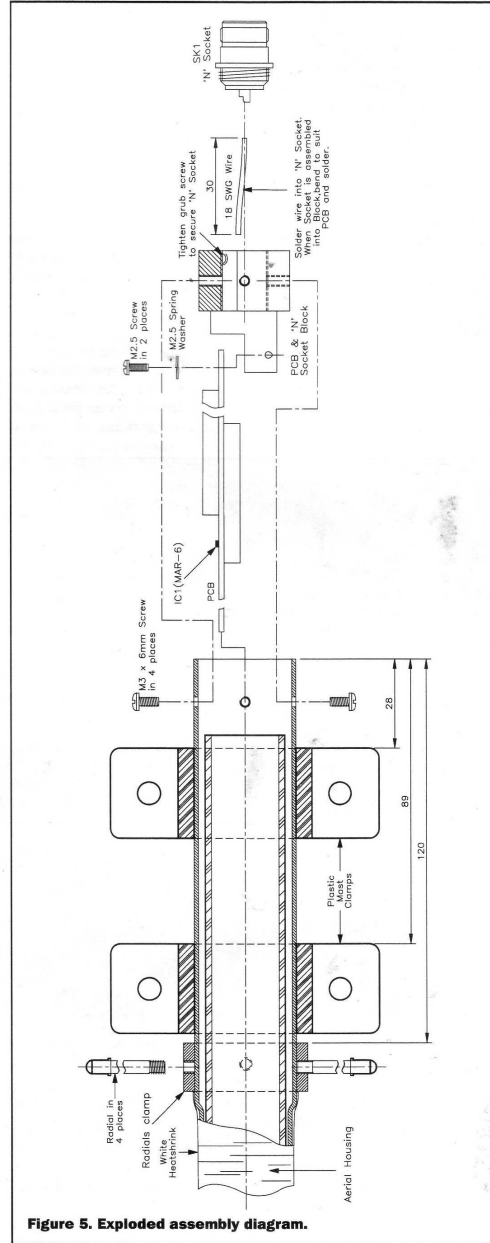

Figure 5. Exploded assembly diagram.

Next, with a 15 to 18W soldering iron (fitted with a small bit) and a pair of tweezers or snipe-nose pliers, fit the MAR-6 IC, IC1, as shown in Figure 3 and Photo 1. A white marker on the body of the device indicates the RF input lead. Another method of identifying the RF input lead, is that the end of the lead is cut off at an acute angle. Holding the body of IC1 with the tweezers/pliers, solder it into place.

The final procedure is to prepare and fit the metal end block assembly, as shown in Figure 5, the exploded assembly diagram. First, take the N-type chassis socket, SK1, and discard its fixing nut and solder tag. Then cut a 30mm length of 18swg wire from the piece supplied in the kit and solder it to the centre connection of SK1. The metal end block should be supplied with a 3mm grub screw already fitted. Ensuring that this grub screw is sufficiently released, screw the N-type socket into the metal block. Using a large pair of pliers, you

must tighten up the socket as much as you can without damaging its threads. The grub screw is now fully tightened (using an allen-key), acting as a secondary locking device on the N-type socket; this should prevent it from becoming loose if the N plug on the down lead is frequently removed. Ensuring that the aerial PCB is the correct way round, secure it to the metal block using the M2.5 hardware, as shown in Figure 5. Finally, bend down the wire from the N-type socket into the slot and onto the surface of the PCB, and solder it – see Photo 2.

This completes the assembly of the aerial PCB, and you should now check your work very carefully, making sure that all the solder joints are sound – no dry (dull/crystalline-looking) joints should be present. Further information on soldering and assembly techniques can be found in the Constructors' Guide included in the kit. Photos 3 to 6 show the completed PCB in clear detail.

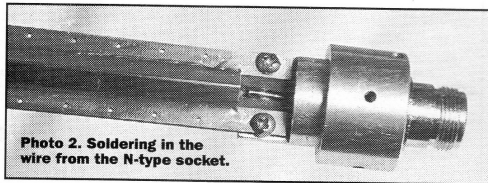

Photo 2. Soldering in the wire from the N-type socket.

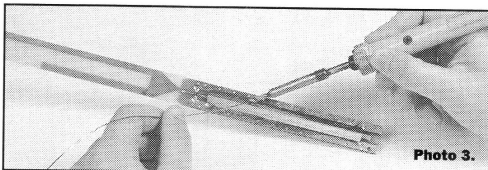

Photo 3.

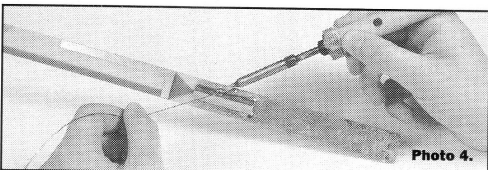

Photo 4.

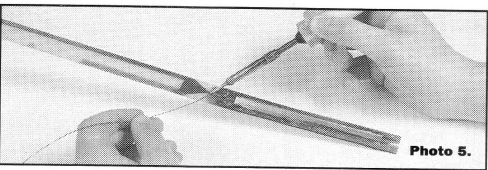

Photo 5.

Aerial PSU Interface PCB Construction

Refer to Figure 6, showing the PSU Interface PCB legend and track. The majority of the components used in the PSU Interface are surface-mount devices (SMDs), apart from D1, a standard silicon diode,

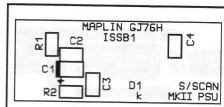

Figure 6. PSU Interface PCB legend and track.

which is the reverse polarity protection device on SK3. DO NOT fit D1 until it is called for in the final assembly stage.

A sequence of photographs show how to typically mount the SMDs, by first wetting one of the components' pads with solder as shown in Photo 7a (see page 6), holding components in position with tweezers, re-flowing the solder to wet the component as shown in Photo 7b, and then making the opposite joint of the component, as shown in Photo 7c. The completed PSU Interface PCB is shown in Photos 7d & 7e.

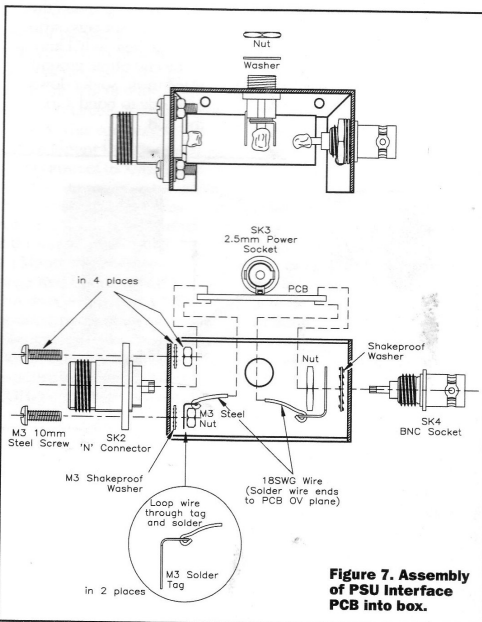

Figure 7. Assembly of PSU Interface PCB into box.

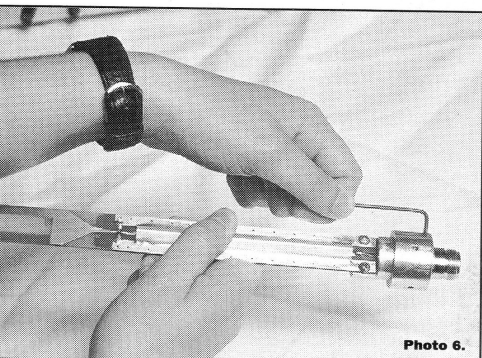

Photo 6.

Photo 3 to 6. Assembly of the Aerial PCB. Note use of a low power soldering iron when soldering in the MAR-6 chip.

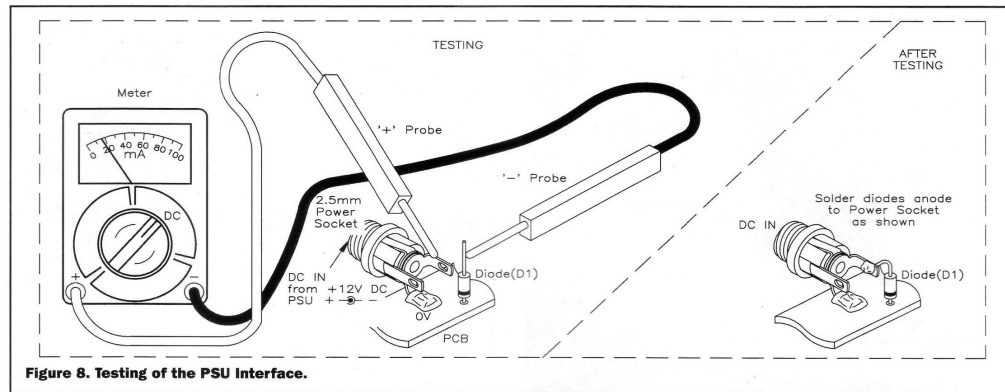

Figure 8. Testing of the PSU Interface.

Aerial PSU Interface Assembly

The three sockets are mounted onto the PSU Interface box in their correct locations, with the relevant hardware, see Figure 7. The N-type aerial socket, SK2, is fixed using four M3 × 10mm bolts, four shakeproof washers and four M3 nuts. In addition, two M3 solder tags are fitted at the locations shown. The BNC receiver socket, SK4, is a single hole fixing type; ensure that its solder tag is at the position shown. The 2.5mm DC power input socket, SK3, is also a single hole fixing type, and its tags must be positioned as shown in the diagram. Make certain that all the hardware is fully tightened up and the solder tags are in their correct positions.

Position and solder into place the PSU Interface PCB assembly, as shown in Figure 7. The centre pin of the N-type socket, SK2, should be soldered to the large pad near to the SMD resistor, R1. The centre pin of the BNC socket, SK4, should be soldered to the large pad near to the SMD capacitor, C4. The middle tag of the 2.5mm socket, SK3, goes to the large ground pad at the centre of the PCB. Using three 15mm lengths of the 18swg wire supplied in the kit, prepare and solder them to the three solder tags on the sockets, as also shown in Figure 7. Bend down the wires onto the surface of the ground plane track on the PCB and solder them into place.

Finally, fit the 1N4001 diode, D1, so its cathode (K), or banded end is soldered to the PCB – see Figure 8. DO NOT connect or solder its anode lead to the DC power input socket, SK3, until instructed to do so during the testing procedure.

Testing Procedure and Final Assembly of the Aerial and PSU Interface

Before you commence the testing procedure, you must first prepare two RF coax connecting cables. You will need a lead from the output of the PSU Interface to the aerial input of your receiver. On one end, you must fit a 50Ω BNC plug, as it keeps the lead as standard as possible and if required, an adaptor is used to obtain the correct connection, N, PL259, TNC, etc. The type of cable must be 50Ω RF coax and be cut to a length to suit your requirements (100mm to 1m). Remember, connecting cables have losses which increase with length and frequency, so make the lead only as long as you need it. With the second lead, you have the option of making a short temporary test cable, or preparing the main aerial down lead if you know its final length requirement. Depending on its length and the upper frequency of your receiver, you should consider the choices of coax cable and N-plug shown in Table 1.

Coax	Length	Frequency	N-plug
RG58 (XR19V)	3m	2,000MHz	N-050 (FJ77J)
RG58 (XR19V)	10m	1,000MHz	N-050 (FJ77J)
RG58 (XR19V)	20m	500MHz	N-050 (FJ77J)
UR67 (XR63T)	10m	2,000MHz	N-011 (FJ78K)
UR67 (XR63T)	30m	1,000MHz	N-011 (FJ78K)
UR67 (XR63T)	60m	500MHz	N-011 (FJ78K)

Table 1. Choosing appropriate coax cable and N-plugs.

The initial DC testing procedure can be undertaken using the minimum amount of test equipment. You will need a multimeter and a power supply capable of providing a regulated +12V DC at up to 300mA – see Figure 8. All the following readings are taken from the prototype using a digital multimeter, some of the readings you obtain may vary slightly depending upon the type of meter used.

When testing the aerial, it has to be pre-tested outside the aerial housing before the final assembly, but the first part to be tested is the PSU Interface.

The first test is for any short circuits. Assuming that the PSU Interface is built up in its box, but without the lid fitted, you should obtain resistance measurements before applying power to the unit.

Using a multimeter on the ohms range and applying the test probes either way around, you should see the following readings;

1. Metal box to anode of D1 = open circuit (> 20MΩ).
2. Centre pin of N socket to box = open circuit.
3. Centre pin of BNC socket to box = open circuit.
4. Centre pin of N to centre pin of BNC = open circuit.
5. Body of N socket to body of BNC socket = short circuit (< 0.3Ω)

We now carry out similar tests on the actual active aerial on the N-type socket SK1 at the base of the aerial PCB assembly;

1. Body of N socket to metal end block = short circuit.
2. Centre pin of N socket to body of N socket = approximately 1k2.

Using the N to N coax cable, connect it between SK1 on the aerial and SK2 on the PSU Interface. Set your multimeter to read DC current. Next, apply power (+12V DC) to SK3; connect your multimeter's test probes to the anode of D1 and the centre tag of SK3 – see inset of Figure 8. When powered up you should observe a current reading of approximately 17mA. Power down the unit and remove the meter, then solder the anode lead of D1 to SK3 as shown in Figure 8. Set your multimeter to read DC Volts. Connect the negative test probe to the metal box and positive to the centre pin of the N socket SK2. When powered up you should observe a reading of approximately 3.6V DC, move the positive probe to the centre pin of the BNC socket SK4. No DC voltage should be present on this socket, however if you are using a high input impedance meter you may get a small floating reading. If the unit passed all its DC tests you can fit the lid on the box and connect the BNC to BNC coax cable to SK4.

The only way of testing the radio reception of the aerial is to either connect it to a spectrum analyser or failing that, to a wide range scanner receiver. Tune to something that you would normally pick up on the whip aerial on the scanner, and when you change over to the Super Scan MkII it should be of

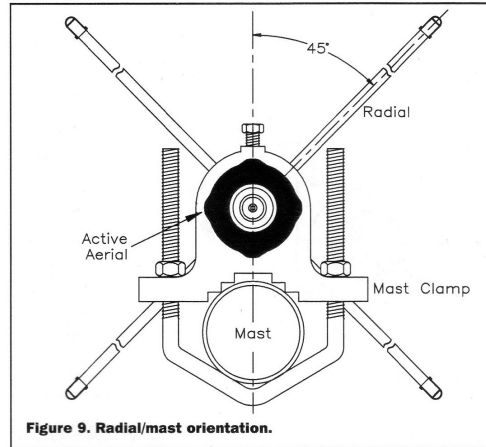
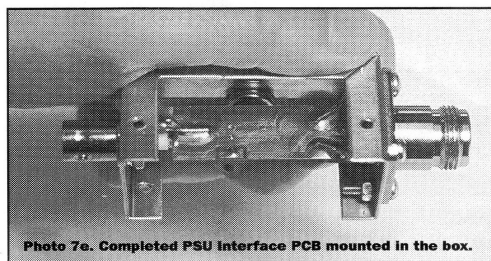
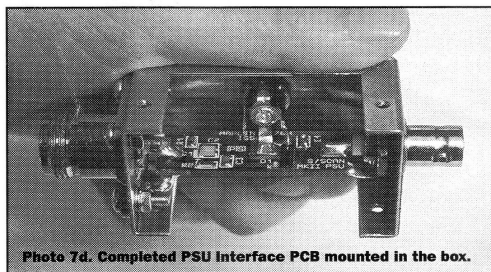
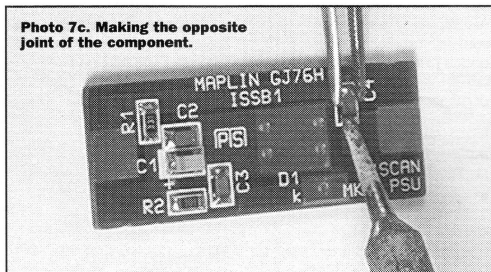
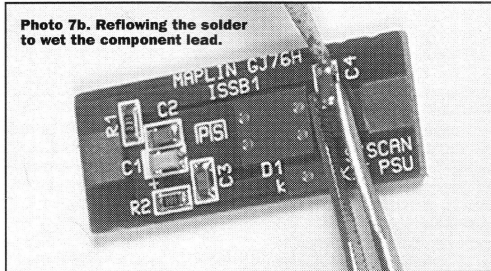
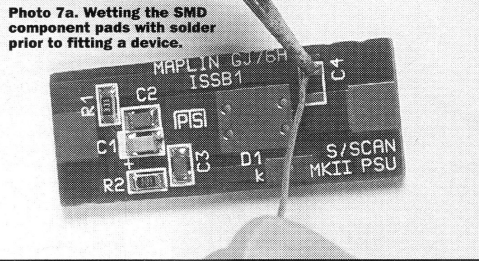

a relatively similar strength, or stronger. Power down the unit and disconnect the N cable from the aerial, this completes the testing procedure.

Assemble the aerial housing with the groundplane radials and mast clamps as shown in Figure 9. NOTE that the groundplane radials are at 45° to the mast clamps and ensure that the spacing between the components are as shown in Figure 5.

Slide the aerial PCB assembly into the housing, see Photo 8. Rotate the N socket until all the M3 tapped holes in the metal end block align with the holes in the housing. Using the four M3 by 6mm bolts, secure the

end block. The bolts should be tightened in turn to ensure the end block is held centrally in the aerial housing. This can be adjusted by looking at the width of the slight gap between the end block and the housing.

Before fitting the heat-shrink material, make sure that the four M3 bolts are fully tightened. When using a screwdriver, it is possible to leave a sharp edge on the head of the bolt, if heat-shrink is then applied over these, as it shrinks, it will puncture and tear. So, after tightening, make absolutely sure that the bolt heads are smooth; if not, use a piece of emery paper or a file to smooth off any rough edges.

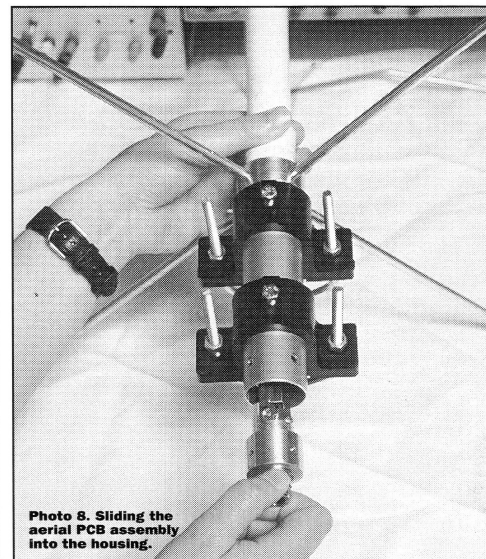

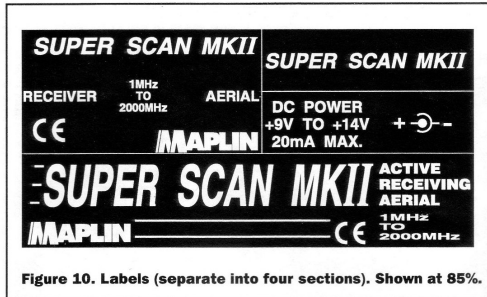

Figure 10. Labels (separate into four sections). Shown at 85%.

Fit the heat-shrink sleeving over the base of the aerial as shown in Photo 9, making sure that it covers the four M3 bolt heads and the end of the metal tube. Do not overheat the heat-shrink material, it only needs to mould itself over the aerial; excessive heat will weaken it and cause it to split.

If a proper heat-gun is not available, then either a heat-gun of the paint stripping variety (the heat from which is very strong) or an efficient hairdryer at its maximum setting will suffice. After the heat-shrink sleeving has cooled, trim off any excess from the end of the aerial base, see Photo 10. Additional long-term protection against the elements can be provided by smearing silicone sealant between the metal end block and the base of the tube, see Photo 11.

Finally, to finish off the project, the sticky label supplied with the kit (which is printed in four parts – see Figure 10) has to be cut up with a pair of scissors and fitted to the aerial and PSU Interface, see Photos showing the completed units. The top right-hand portion of the label can be used to identify the download as being for the Superscan MkII aerial, to avoid confusion with other coax leads that may be nearby.

This completes the assembly of the project, and you should now check all the work you have done and give the aerial one last receiver test before installing the system.

Aerial Installation

The aerial installation is straightforward and follows normal practice for small aerials. First, select a location on your building, preferably away from power and telephone lines, etc., that might interfere with reception. With safety in mind when climbing ladders, make sure that the base of the ladder will not slide about. Next, install a wall mounting

bracket (XQ53H), or chimney lashing kit (XQ57M), as required. Then attach the Super Scan MkII to a suitable length of aluminium tubing (XQ62S) to act as the support mast, see Figure 11.

Refer to the system wiring diagram shown in Figure 12 when wiring in the Superscan MkII aerial and its PSU Interface unit. Connect the prepared coax to the N-type socket at the base of the aerial and secure the cable to the mast using cable ties or insulation tape. Next, fit the mast assembly to the bracket and tighten up the clamps. A good tip is to lightly grease the threads and the nuts on both clamps, as this will make it easier to undo in the future. Run the coax down the wall to the required receiving location (fixed in position by clips) and if necessary, drill a hole into the building.

The coax is connected to the aerial PSU Interface by means of another N-type plug, and a coax connection with BNC plugs on each end runs to the scanner receiver. Finally, connect the regulated PSU (set to 12V) with centre pin positive on the 2.5mm plug to the aerial PSU Interface.

Using the Super Scan MkII

There are, generally, two main categories of scanning receivers – portable hand-held and desktop models. Both these types include scanners that are FM/AM only, and others which cover modes such as SSB and CW. The earlier and cheaper type of scanning receiver did not have full coverage of the HF/VHF/UHF spectrum, the gaps in the frequency ranges being dependent on the type and make of scanner. A modern top-of-the-range scanning receiver can now have a frequency coverage from virtually 0kHz to in excess of 2,000MHz (2GHz), and most will receive NFM, WFM, AM, USB, LSB and CW.

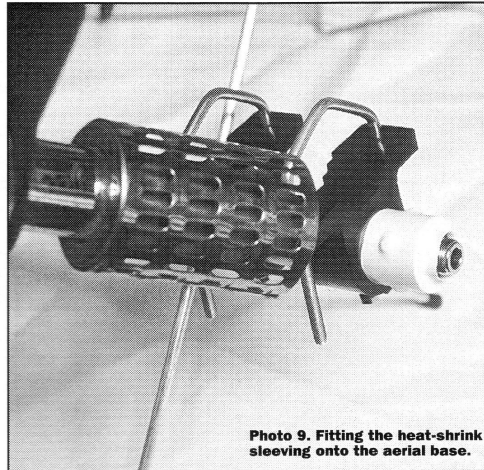

Photo 9. Fitting the heat-shrink sleeving onto the aerial base.

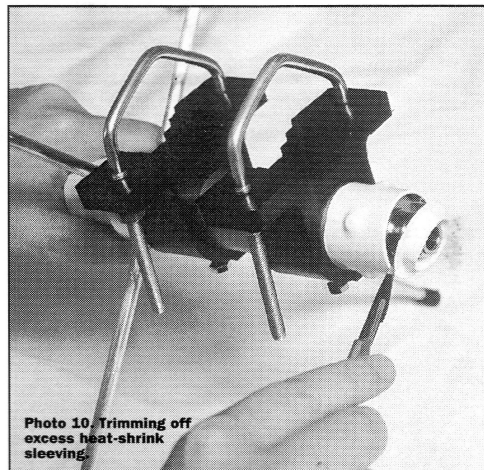

Photo 10. Trimming off excess heat-shrink sleeving.



Photo 11. Extra protection against the elements can be achieved by smearing silicone sealant between the metal block and the base of the tube.

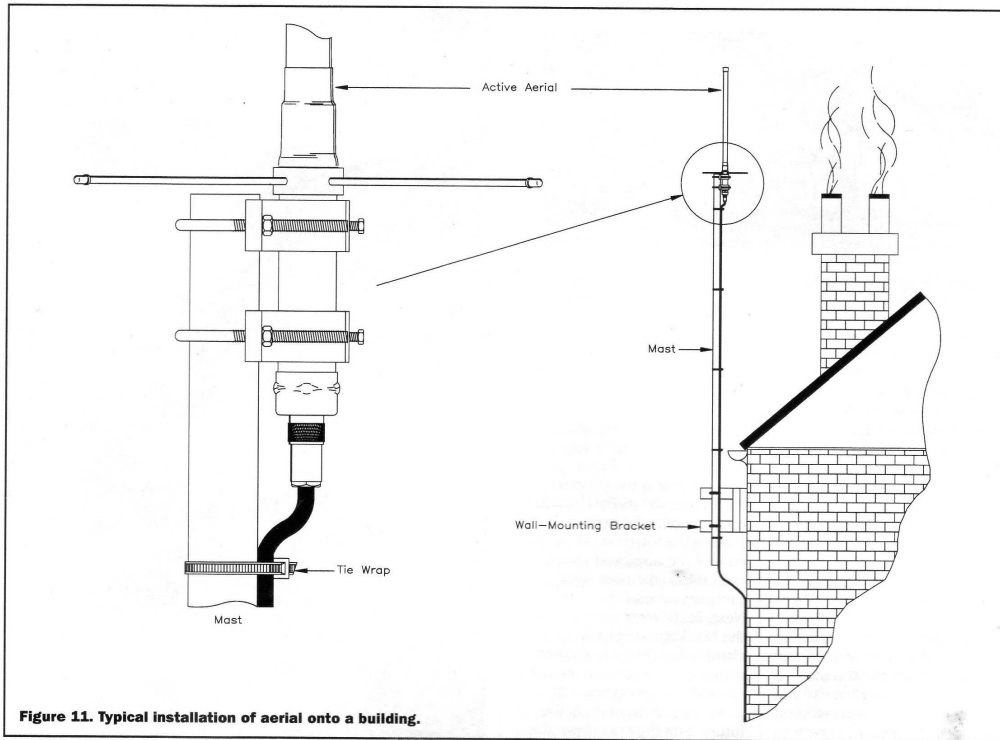

Figure 11. Typical installation of aerial onto a building.

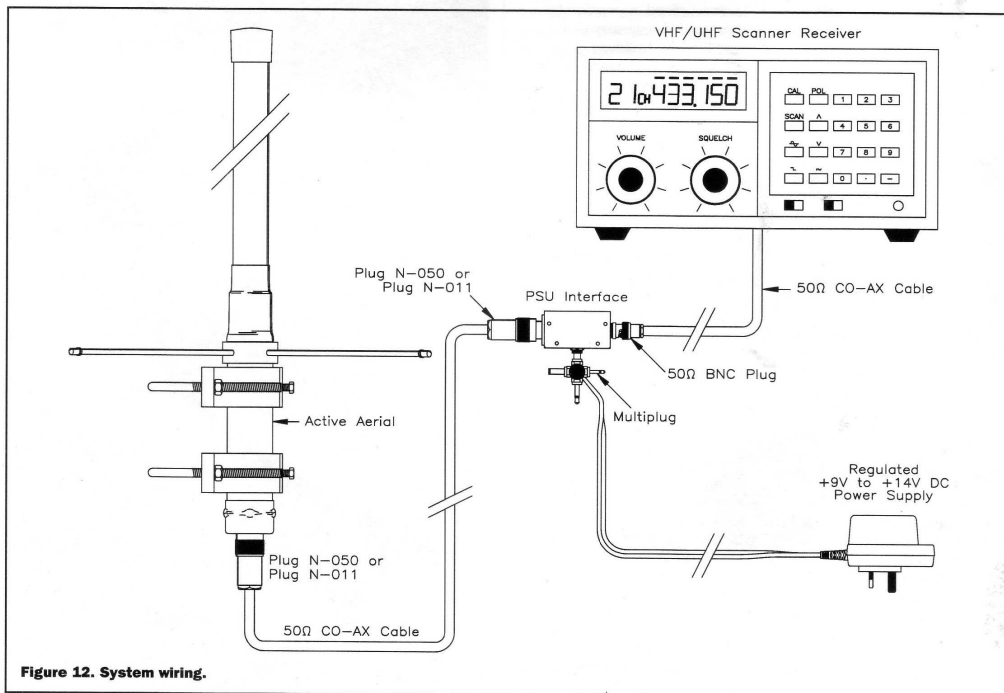
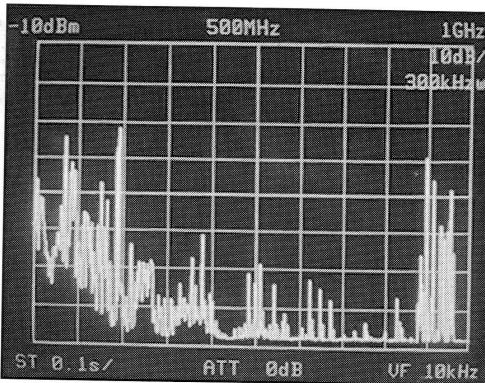

Figure 12. System wiring.

Photo 12. Frequency scan showing the greatly varying strengths of radio signals being received.



Over such a large frequency range there are many radio signals at greatly varying strengths, see Photo 12. All radio receivers can be overloaded by strong local RF signals, resulting in distorted or scrambled reception. To overcome this problem most receivers employ some form of Automatic Gain Control (AGC). However, extremely strong RF signals can fall outside the range of the AGC circuit and require additional attenuation. This can take the form of a manual variable RF gain control, or switched RF attenuator. Nearly all scanners are fitted with a -10dB attenuator switch, please refer to your scanners operation manual.

The completed Superscan MkII project and a selection of current typical scanners and scanner books are shown in Photo 13. There are a

number of books dedicated to the scanner enthusiast, some of which are not always appreciated by the authorities. Responsible scanning must be the order of the day, as hefty fines and confiscation of equipment can be the result of insensitive listening and divulging of classified information to third parties.

Further Reading

Short Wave International Frequency Handbook, Bill Laver (Order Code WT73Q)
Scanning Secrets, Mark Francis and Bill Laver (Order Code YE84F)
Scanner 3 - Putting Scanners into Practice, Peter Rouse GUIDKD (Order Code WP47B)
An Introduction to Scanners and Scanning, I. D. Poole (Order Code WZ62S)
The VHF/UHF Scanning Frequency Guide, Bill Laver (Order Code WT70M)



PROJECT PARTS LIST

RESISTORS

R1	330Ω Surface-mount	1	(DJ09K) ★
R2	100Ω Surface-mount	1	(DJ07H) ★

CAPACITORS

C1	1μF Surface-mount Ceramic	1	(DK22Y) ★
C2,3	100nF Surface-mount Ceramic	2	(DJ00A) ★
C4	10nF Surface-mount Ceramic	1	(DH97F) ★

SEMICONDUCTORS

D1	1N4001	1	(QL73Q)
IC1	MAR-6	1	(DK24B)

MISCELLANEOUS

SK1	N-type Chassis Socket	1	(FJ79L)
SK2	N-type Square Chassis Socket	1	(FJ80B)
SK3	2.5mm Panel-mounted Power Socket	1	(JK10L)
SK4	50Ω Round BNC Socket	1	(HH18U)
	6.4 x 6.4 x 305mm Brass Angle	1	(HZ65V)
	Aerial Housing	1	(GA37S)
	PSU Box	1	(GA38R)
	M3 10mm Steel Screw	4	(JY22Y) ★
	M3 Steel Nut	4	(JD61R) ★
	M3 Shakeproof Washer	4	(BF44X) ★
	M3 Solder Tag	2	(LR64U) ★
	M3 6mm Steel Screw	4	(JY21X) ★
	M2.5 6mm Steel Screw	2	(JY29G) ★
	M2.5 Spring Washer	2	(JD97F) ★
	18swg 1.25mm Tinned Copper Wire	1 length	(BL12N) ★
	Lay-flat Heat-shrink Tubing Type CHT57	1 length	(BA05F) ★
	PCB	1	(GJ66W)
	PSU PCB	1	(GJ76H)
	Label	1	(KV21X)
	Instruction Leaflet	1	(XZ27E)
	Constructors' Guide	1	(XH79L)

OPTIONAL (Not in Kit)

Low Capacitance Screened Cable	As Req.	(XR19V)
UR67 RF Cable	As Req.	(XR63T)
N-type Plug N-050	2	(FJ77J)
N-type Plug N-011	2	(FJ78K)
50Ω BNC Plug	2	(HH17T)
N-type Male to BNC Adaptor	1	(FJ82D)
UHF Male to BNC Female Adaptor	1	(YW05F)
AC Adaptor Regulated	1	(YB23A)
Tie-wrap	As Req.	(FE00A)

The Maplin 'Get-You-Working' Service is available for this project, see Constructors' Guide or current Maplin Catalogue for details.
The above items (excluding optional) are available as a kit.

Order As LU33L (Superscan MkII Aerial)

Order As AM37S (Ready-assembled Superscan MkII Aerial)

Please note: Items in the Parts List marked with a ★ are supplied in 'package' quantities (e.g., packet, strip, reel, etc.) see current Maplin Catalogue for full ordering information.

The following new items (which are included in the kit) are also available separately.

Superscan MkII Aerial PCB **Order As GJ66W**
 Superscan MkII PSU PCB **Order As GJ76H**
 Superscan MkII Label **Order As KV21X**
 Superscan MkII Aerial Housing **Order As GA37S**
 Superscan MkII PSU Box **Order As GA38R**

Scanner books

See the Books and Technical Data section of the Maplin MPS Catalogue.

Scanners

See the Radio Communications section of the Maplin MPS Catalogue.

MAPLIN